

**GC20DLH THRU GC20MLH**  
**Low VF Rectifier Diode**

● **FEATURES**

- \* Halogen-free type
- \* Lead free product, compliance to RoHS
- \* GPRC (Glass passivated rectifier chip) inside
- \* Glass passivated cavity-free junction
- \* Lead less chip form, no lead damage
- \* Low forward voltage drop
- \* Plastic package has Underwriters Laboratory Flammability Classification 94V-0

● **APPLICATION**

- \* General purpose rectification
- \* Surge absorption

● **MECHANICAL DATA**

**Case :** Packed with FRP substrate and epoxy underfilled

**Terminals :** Pure Tin plated (Lead-Free), solderable per MIL-STD-750, Method 2026.

**Polarity :** Cathode Band, Laser marking

**Weight :** 0.02 gram

● **PACKING**

- \* 3,000 pieces per 7" (178mm ± 2mm) reel
- \* 4 reels per box
- \* 6 boxes per carton

● **OUTLINE DIMENSIONS**

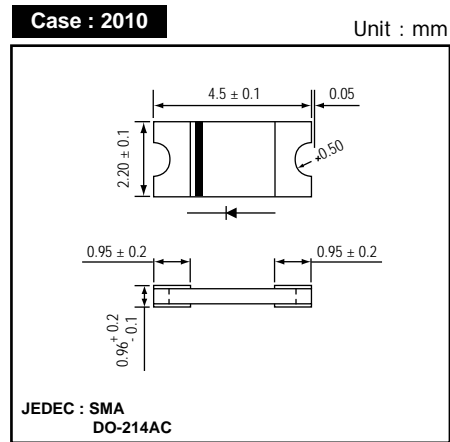

● **MARKING**

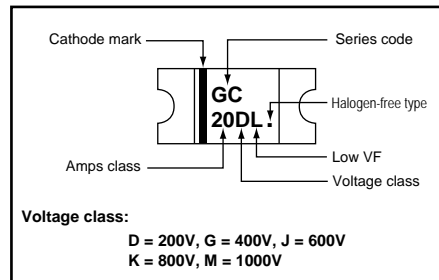

**Absolute Maximum Ratings (Ta = 25 °C)**

ITEM	Symbol	Rating					Unit
		GC20DLH	GC20GLH	GC20JLH	GC20KLH	GC20MLH	
Repetitive peak reverse voltage	VRRM	200	400	600	800	1000	V
Average forward current	IF(AV)	2.0					A
Peak forward surge current (8.3ms single half sine-wave)	IFSM	65					
Operating junction temperature Range	Tj	-65 to +175					°C
Storage temperature Range	TSTG	-65 to +175					

**Electrical characteristics (Ta = 25 °C)**

ITEM	Symbol	Conditions	Min.	Typ.	Max.	Unit
Forward voltage	VF	IF = 2.0A	-	0.90	0.92	V
Repetitive peak reverse current	IRRM	VR = Max. VRRM , Ta = 25 °C	-	0.08	5	uA
Junction capacitance	Cj	VR = 4V, f = 1.0 MHz	-	16	-	pF
Thermal resistance	Rth(JA)	Junction to ambient (NOTE)	-	88	-	°C/W
	Rth(JL)	Junction to lead (NOTE)	-	11	-	

NOTES : Thermal resistance from junction to ambient and from junction to lead P.C.B. mounted on 0.2 x 0.2" (5.0 x 5.0mm) copper pad areas.

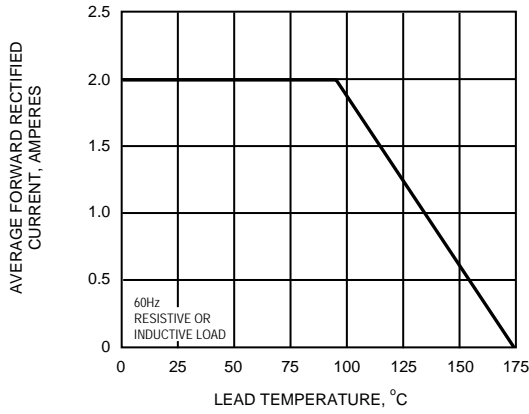
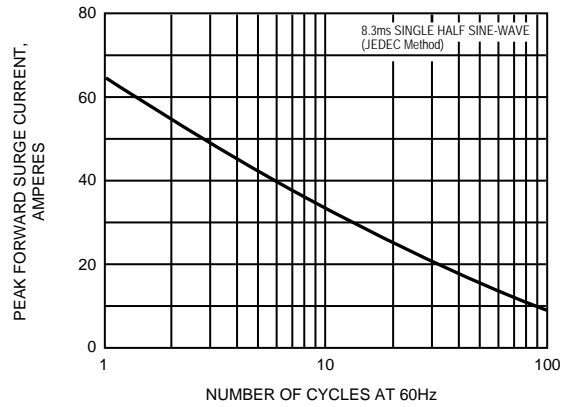
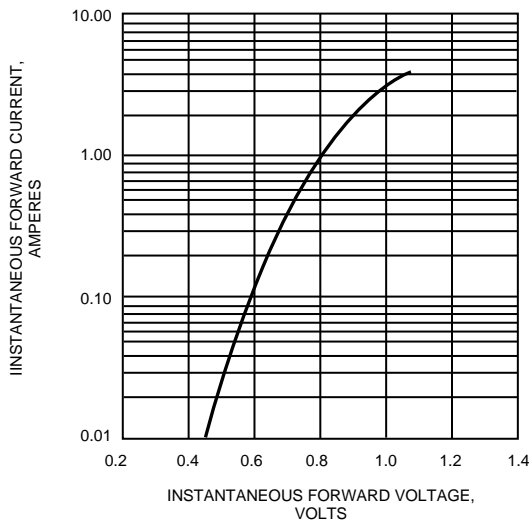
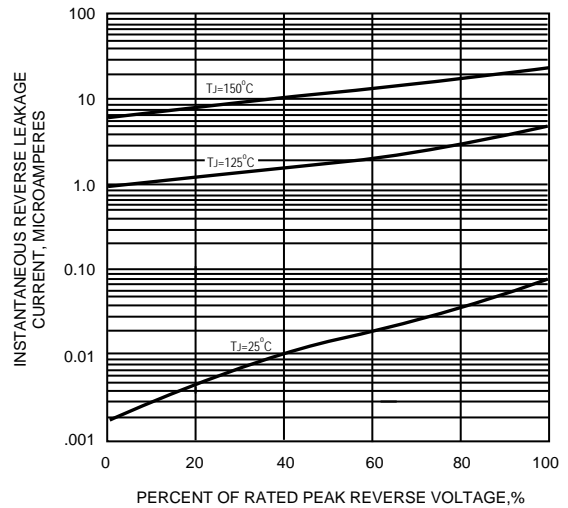
**FIG.1 - FORWARD CURRENT DERATING CURVE**

**FIG.2 - MAXIMUM NON-REPETITIVE PEAK FORWARD SURGE CURRENT**

**FIG.3 - TYPICAL INSTANTANEOUS FORWARD CHARACTERISTICS**

**FIG.4 - TYPICAL REVERSE CHARACTERISTICS**

**FIG.5 - TYPICAL JUNCTION CAPACITANCE**
